

Transport and storage

Transport and store in upright position. Protect from direct sunlight and rain if stored outdoors. Do not store pallets on top of one another.

Intended use

Saneri is suitable for built-up roofing systems with sealed joints in new construction and reroofing applications, with a minimum pitch of 1:20 (approx. 3°). The ratio 1:20 means that the roof slope has a fall of one metre over a span of ten metres.

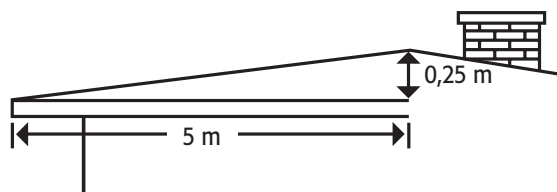

Method of use

Saneri is a high-quality, pliable, non-split cap sheet membrane, ideally suited for self-builders. The long side edge have a self-adhesive strip for easy jointing and the end joints are sealed with an appropriate sealing compound. Saneri is fixed to the substrate with roofing nails.

Product data

Roll weight: 35 kg
 Bitumen type: SBS-elastomer bitumen
 Reinforcement: net reinforced non-woven polyester
 Surface material: slate granules
 Fire rating: B(t2)

MATERIALS AND TOOLS

For the roofing of a conventional pitched roof you need the following materials and tools. Ask for them at your local hardware store.

Materials:

- Quantity of Saneri needed is approx. 1.15 x roof area
- For valleys KATEPAL underlay sheet, 1m/running metre of valley
- Sealing Compound K-36, 5-10 litres/100 m² of roof area depending on the number of extension joints, upturns and lead-throughs
- Roofing nails (length 25-35 approximately 4.5-6.0 kg/100 m² of roof area (the nails must penetrate through the roof deck boarding)
- If needed also eave drips, suction ventilators, lead-through sleeves and gutters.

Tools:

- Blade knife, hammer, measuring tape, steel spatula and cartridge gun.
- Use a hot air gun if working in cold weather (below +10 °C).

Instructions for installation and use

On the reverse of the wrapper there are detailed instructions for the installation of Saneri roofing. Please read the instructions prior to starting work! If installing roofing at low temperatures (below +5 °C) the rolls should be opened to straighten out for a few hours before fixing the sheets. In order to avoid colour differences, always open the felt rolls in the same direction.

SANERI ROOFING SYSTEM WITH SEALED JOINTS

INSTALLATION INSTRUCTIONS

ENG

SUBSTRATE

The substrate for the roofing must be stable, unbending, smooth and dry. It can be made of air-dry, rough-sawn T&G boards (width approx. 95 mm), square-sawn rough boards (width approx. 100 mm) or moisture resistant building panels. The thicknesses of different substrates are given in the table below. Allowance must be made for possible expansion of boards and panels by leaving a sufficient gap between them.

Thickness of roof deck

Supports c-to-c mm	Thickness of rough T&G boarding mm	Thickness of rough- sawn boarding mm	Thickness of building panels mm
600	20	22	12
900	23	25	18
1200	30	32	21

MATTERS TO OBSERVE IN REROOFING WORK

Saneri can also be installed directly on existing bitumen felt roofing with an even surface. Any air pockets or creases in the old roofing are to be slit, glued and nailed flat to the substrate.

Ventilation of roof structure

Ensure that the space below the roof deck is dry and sufficiently ventilated. There must be sufficient air vents/gaps at the gable ends and eave soffits. If necessary, ventilation can be improved, for example, by installing a suction ventilator near the ridge.

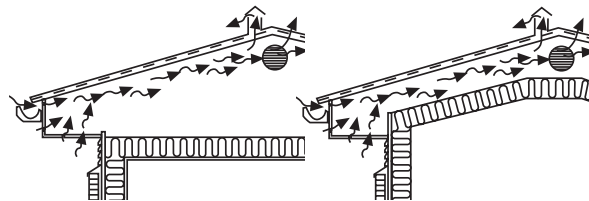

Condition of roof deck boarding

The substrate must be stable and unbending. Depressions, deformations and bending indicate that the roof deck boarding has serious defects, which must be repaired before reroofing.

Flashings

Flashings commonly have to be renewed when a roof is renovated. It is recommended to have a roofing professional install roof flashings. We recommend the installation of a drip at the eaves and verges. Katepal can supply suitable Sheetmetal drips.

Gutters

Ensure that the gutters, downpipes, and their fixings are in good condition. It makes sense to renew these, too, when you are renovating your roof.

Weatherproofing of lead-throughs

Ensure that the seals and collars of pipes, TV aerial cables, electrical wiring, any roof drains, and other lead-throughs are in good condition. Anticipate that they may have to be replaced. Check also the weatherproofing of any rooflights and ensure that the bitumen felt upturns around chimneys and other large penetrations are in good condition.

Cleaning the roof

The substrate must be clean and dry. Any debris, loose granule surfacing, moss, organic matter, etc. must be removed.

WEATHER CONDITIONS DURING INSTALLATION

If air temperature falls below +10 °C at the time of installation, the adhesive surfaces should be heated with a hot air gun. During installation work the weather must be dry, and work should not be carried out if rain is imminent. If installation work is temporarily discontinued, ensure that, in case of rain, water can not get under the roofing. When installing roofing at low temperatures (below +5 °C), the rolls should be opened to straighten out for a few hours before fixing. In order to avoid colour differences, always open the felt rolls in the same direction.

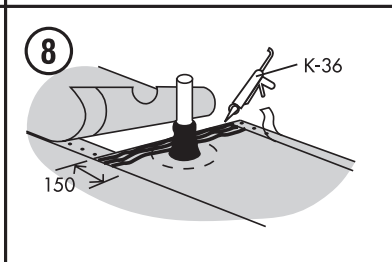
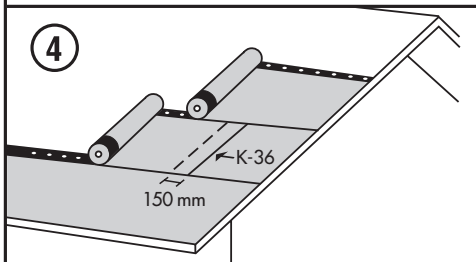
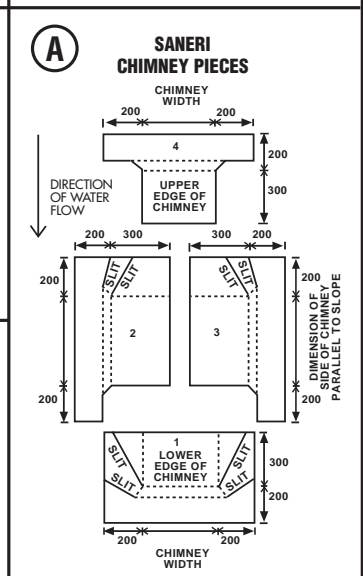
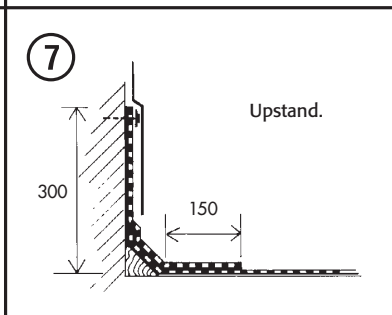
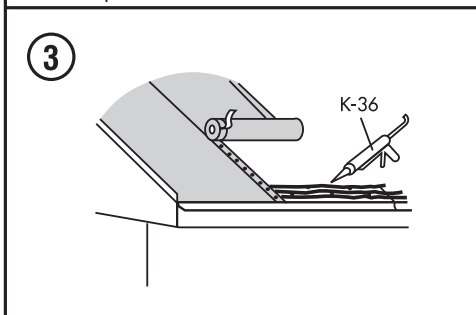
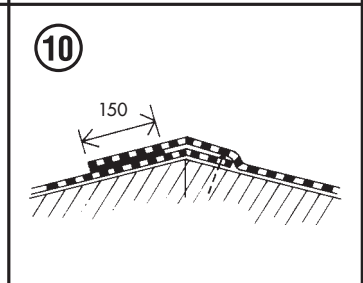
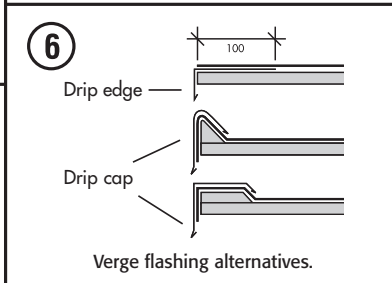
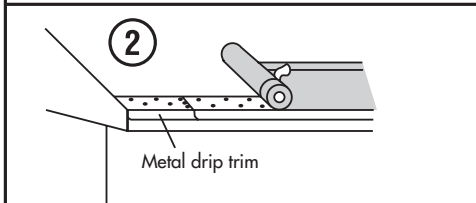
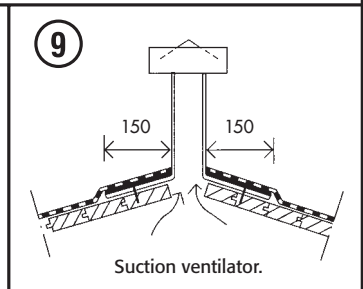
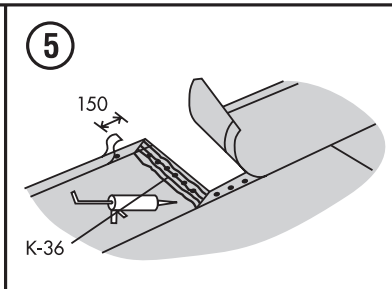
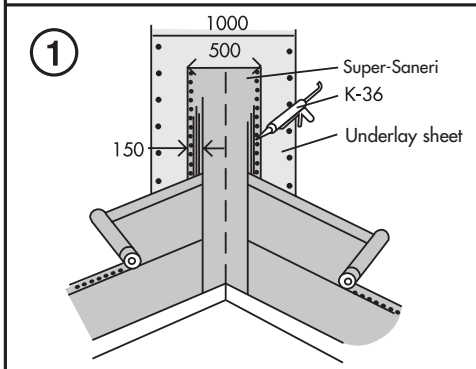
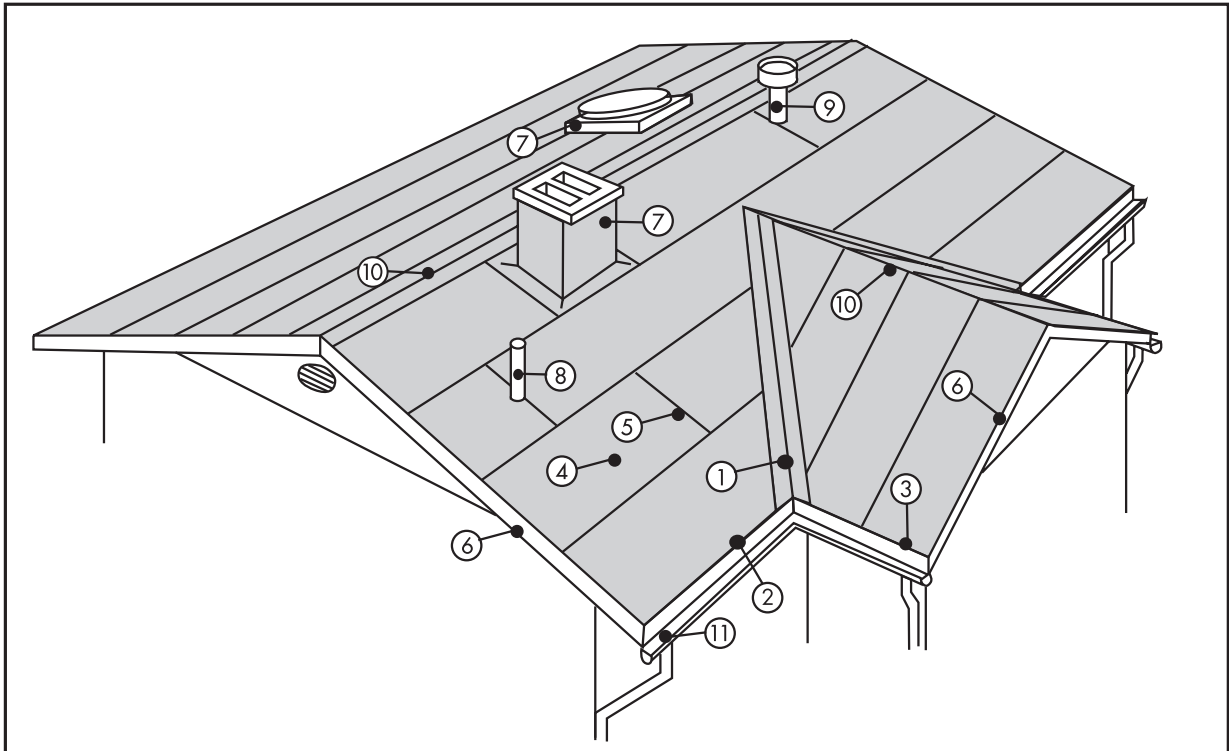

INSTALLATION

CAUTION! Move carefully on the roof. Three meters is a long way to fall! Please read the installation instructions prior to commencing work.

General

Saneri should be installed in such a way that the overlapping membrane of a joint is never on the side of the fall. The sheets may be installed parallel to the ridge (horizontal installation) or perpendicularly against the ridge (vertical installation). For steep sloping roofs (> 1:3) we recommend vertical installation to ensure that the membranes are installed in straight lines to avoid the risk of creasing. (On steep sloping roofs the sheets easily slip downwards off the horizontal line.) Over old bitumen felt roofing Saneri is installed parallel to the existing roofing so that the longitudinal joints do not coincide. The clout roofing nails must penetrate through the deck boarding. (Short nails will gradually become dislodged due to the moisture movement of wood.)

1. Valleys

If the roof has valleys, first install Katepal Underlay Sheet. Nail it to the substrate from its sides at 20 cm intervals. Then install drip edges along the eaves as instructed in Section 2. (We also recommend the installation of drip edges at the verges). Then lay a 50 cm wide strip of Liimari along the valley. Nail the strip from the edges to the substrate at 10 cm intervals and glue the bottom end to the drip edge with Sealing Compound K-36. The membranes covering the slope should overlap the Saneri valley sheet by 15 cm and their ends should be cut parallel to the valley. Extrude wide bands of Sealing Compound into the overlap joint and press the membranes together.

2. Eaves, horizontal installation

Install the drip edge for the eaves over the roof decking or old bitumen felt roofing. Nail the upper part of the drip edge to the deck with roofing nails at approx. 10 cm intervals in a zigzag pattern. Overlap the end joints by 5 cm and drive nails through both metal sheets. Verge flashing can be installed in the same way as eaves flashing. Align the edge of the Saneri sheet with the eave so that the adhesive strip on the underside covers the upper side of the flashing. In order to avoid creases, it is important always to install Saneri sheets in a straight line even if the eaves line is not absolutely straight.

NOTE: Only remove the protective film on the top surface after having aligned the next sheet.

3. Eaves, vertical installation

First install the drip edges as instructed in Section 2. Align the edge of the Saneri sheet with the verge so that the adhesive strip on the underside of the sheet becomes fixed to the drip edge. If no drip edge is installed, fold the edge of the Saneri sheet over the blocking piece along the verge and 1-2 cm below the underside of the roof deck boarding. The membrane is bonded to the blocking piece and secured by nailing to the outer edge of the verge. Once the installation of Saneri has progressed to the second gable end, bond the edge of the last sheet with Sealing Compound, to a width of approx. 15 cm to the verge flashing or the roof deck. At the eaves the ends of the roofing sheets are bonded to the metal drip edge with Sealing Compound. In vertical installation, too, you must ensure that the roofing sheets are laid in straight lines so as to avoid creasing. **NOTE: Only remove the protective film on the top surface after having aligned the next sheet.**

4. Aligning and fixing

Start the installation of Saneri by aligning the first sheet with the eave or the verge, depending on the direction of installation and lay it in an absolutely straight line. The upper edge (or the inward facing edge in the case of vertical installation) is pre-nailed at approx. 1 m intervals through the protective film of the adhesive strip while ensuring that the sheet is sufficiently tightened. The protective film on the underside of the sheet is removed and the adhesive edge is pressed against the metal drip edge ensuring also that the sheet is sufficiently tight. The next sheet is aligned over the adhesive edge of the previous sheet and pre-nailed in the same way as the first one. The free edge of the sheet is then folded away from the top of the adhesive edge of the previous sheet. The protective film is removed from the pre-nailed edge and it is then nailed at approx. 10 cm intervals, along the middle of the adhesive strip to the substrate. After this, the protective film on the lower edge of the upper sheet is removed and the adhesive strips are pressed together. Ensure that overlapping sheet is laid sufficiently tightly and in a straight line. Continue installation in the same manner up to the ridge or until you reach the opposite end. In this way nails always remain concealed and there are no nail heads visible on the finished roofing.

5. Saneri joints for lengthwise extension are made with 15 cm overlaps. Cut away a triangular piece from one corner of each sheet (at the verge from the one that is between the sheets) and nail the end of the underlapping sheet to the roof deck. Squeeze a few wide strands of Sealing Compound onto the overlap area and press the extension sheet hard onto the adhesive. Remove any surplus adhesive that is squeezed out of the joint. The Sealing Compound will harden to its maximum strength in approx. two weeks. **NOTE: Only remove the protective film on the top surface after having aligned the next sheet.**

6. Install a metal trim over the blocking piece. Different options are displayed here. When using a drip edge, the ends of Saneri sheets (or the edge without adhesive) is bonded to the metal edge with Sealing Compound to a width of 10 cm.

7. Upturns and chimney

Once the roofing work has progressed to the upper edge of a chimney or other large penetration, cut the upturns out of a sheet of Liimari according to Figure A and bond them with Sealing Compound in the numbered order across their entire width to the chimney and over the roofing sheets on the slope (15 cm overlap). Before installing the pieces, create a cove at the abutment by using angle fillets, for example. Always make the actual upturn out of a separate strip of Saneri that extends at least 30 cm above the roof surface and 15 cm over the roof slope sheets. Attach the top edge of the upstand to the chimney, for example, by nailing it to the brickwork joints. Make sure to seal the corners carefully with Sealing Compound and finally protect the upturn with sheetmetal apron flashing.

8. With flue pipes and similar components penetrating the roofing, use flexible rubber collars with a clamping ring and at least 15 cm wide flanges. Install the collar element in place and nail it to the roof deck through the flange. Cut a hole the size of the collar in the Saneri sheet and bond the underlapping sheet to the flange over its entire area with Sealing Compound. Attach the sheets as instructed in Section 5 (extension).

9. If there is a need to enhance the ventilation of the roof space, install a suction ventilator on or near the ridge of the roof. Install this as instructed in Section 8 (collar).

10. When installing roofing on the first slope extend the Saneri sheet some way over the ridge and nail it to the substrate. From the opposite slope extend the sheets 20 cm over the ridge and bond with Sealing Compound to the underlapping sheet to a width of 15 cm. Cut away the adhesive strip of the top surface possibly left exposed.

FINISHING THE ROOFING

Finally ensure the watertightness of the parts of the roof that are most prone to failure:

- edges of upturns
- penetration abutments
- corners and joints of upturns around chimneys and other components
- edges of sheet extension joints.

Finally install flashings.